

# VARIOGATE®



**collini**  
sistemi



# Collini Sistemi

Collini Sistemi distributes on the Italian market innovative and certified products that grant hygiene and safety in all the factories where there is material handling.

Thanks to the excellent solutions we offer, we are in constant contact with companies in the food & beverage, pharmaceutical, packaging and automotive industries.

They submit to us their criticalities in hygiene and safety and we offer them the effective solutions.



This brochure provides you with information about our VARIOGATE® (pallet gates) made to provide protection and safety for open loading areas between different floor levels and platforms. Our high quality products comprise items for use in every industrial environment.

Here you can find an overview of both standard solutions readily available and customized solutions which can be fully adapted to a specific situation. All our products share the same characteristics providing a safe and pleasant workplace while requiring a minimum amount of space.

You will find more details about our VARIOGATE® safety gates for safe working at heights.

# Criteria

To find the best solution for every loading situation using a VARIOGATE®, some important points should be considered first regarding the items to be loaded and the building itself. When assessing the situation Collini Sistemi applies the following criteria:

## **Dimensions:**

The height, width and depth of the load (dimensions), to be transported individually or on a pallet. Note: protruding loads on the pallet should also be allowed for.

## **Installation height:**

The available installation height determines the maximum height of the load.

## **Installation depth (outswing)**

Pivoting gates require extra space to operate.

## **Direction of goods transport**

Determine which direction (backwards or sideways) the load is positioned in and out of the pallet loading gates. A sideways movement requires more depth.

## **Type of transport**

Which type of transport is in use. A fork-lift truck or reach truck requires different facilities than, for example, a travelling crane.

## **(Fire) doors and roll-up doors are in place**

Positioning a pallet loading gate directly next to or behind a door needs special requirements.

## **Situating the device**

Assembly ensures that the front of the gate aligns precisely with the mezzanine floor edge. This is particularly important when loading a pallet from a lower floor. The fork-lift driver places the pallet on the edge of the mezzanine floor. The gate then closes behind the pallet. When the pallet is not in the right position, the gate will not close and the goods cannot be transported.

## **TÜV Certificate**

The TÜV is strongly committed to promoting the safety, quality, reliability and living environment of society and organizations and authorities. All TÜV-tested products ensure that you can be sure of having reliable products, services and suppliers.

The main objective is to provide evidence that companies and products meet the reliability requirements. TÜV identifies throughout assessments the actual risks and weak points in its assessments to arrive at a reliable and safe product.

To ensure safety and quality, VARIOGATE® pallet gates have tested by a comprehensive TUV test which is supported and guaranteed by annual audits. The test results are available on [www.tuv.nl](http://www.tuv.nl).

The report and the certificate are also available on request.





## Standard solutions

Characteristic of the VARIOGATE® series is their compact construction. They require a minimum amount of space so no valuable storage and/or working space is lost. The connection between the separate components is

ingenious, making them easy to operate. The device is shock-resistant and is very durable, even in heavy use. The VARIOGATE® series are available on order and competitively priced. Collini Sistemi can supply every type of

### VARIOGATE® 18-Series

The VARIOGATE® 18-Series is a swing arm pivoting loading gate. Three rectangular frames swing over the sides of the goods.

#### Suitable for loads as follows:

- Height: 1.800 mm
- Choice of Widths: 1.200, 1.600, 2.000 and 2.600 mm\*
- Depth: 1.400 mm

#### Installation space dimensions:

- Height: 2.075 mm
- Width: 1.600, 2.000, 2.400 and 3.000 mm
- Depth: Fixed supports: 800 mm  
Pivoting component: 1.580 mm
- Turning radius: 2.025 mm  
(measured from the floor edge)

\* Widths take the required space for manoeuvring on both sides into account.



### VARIOGATE® 22-Series

The VARIOGATE® 22-Series is a swing arm pivoting loading gate. Three rectangular frames swing over the sides of the goods.

#### Suitable for loads as follows:

- Height: 2.200 mm
- Choice of Widths: 1.200, 1.600, 2.000 and 2.600 mm\*
- Depth: 1.450 mm

#### Installation space dimensions:

- Height: 2.510 mm
- Width: 1.600, 2.000, 2.400 and 3.000 mm
- Depth: Fixed supports: 830 mm  
Pivoting component: 1.617 mm
- Turning radius: 2.203 mm  
(measured from the floor edge)

\* Widths take the required space for manoeuvring on both sides into account.



**VARIOGATE®** including assembly, if desired. The tubular frame sections are supplied in powder coat (Yellow). Other colours are available on request.

The tubular frame sections meet the dutch national safety regulations. Collini Sistemi offers a two-year warranty on every product. Technical drawings are available on request.

### VARIOGATE® 26-Series

Die VARIOGATE® 26-series is a swing arm pivoting loading gate. Three rectangular frames swing over the sides of the goods.

#### Suitable for loads as follows:

- Height: 2.600 mm
- Choice of Widths: 1.200, 1.600, 2.000 and 2.600 mm\*
- Depth: 1.500 mm

#### Installation space dimensions:

- Height: 2.900 mm
- Width: 1.600, 2.000, 2.400 and 3.000 mm
- Depth: Fixed supports: 900 mm  
Pivoting component: 1.785 mm
- Turning radius: 2.470 mm  
(measured from the floor edge)

\* Widths take the required space for manoeuvring on both sides into account.



### VARIOGATE® 26ED-Serie

Die VARIOGATE® 26-series is a swing arm pivoting loading gate. Three rectangular frames swing over the sides of the goods.

Characteristic for deep loads of 2,800 mm

#### Suitable for loads as follows:

- Height: 2.600 mm
- Choice of Widths: 1.200, 1.600, 2.000 and 2.600 mm\*
- Depth: 2.800 mm

#### Installation space dimensions:

- Height: 3.036 mm
- Width: 1.600, 2.000, 2.400 and 3.000 mm
- Depth: Fixed supports: 1.530 mm  
Pivoting component: 2.940 mm
- Turning radius: 3.460 mm  
(measured from the floor edge)

\* Widths take the required space for manoeuvring on both sides into account.



## Special Note

VARIOGATES® do not fall under any EN standard. Collini Sistemi products are supplied in accordance with the laws and regulations on gate systems. Under normal use the equipment does not cause any injury to

bystanders/or users. After delivery and installation Collini Sistemi offers a two-year guarantee over the whole supply programme. This is only applicable in cases of normal use and does apply for components that have been subject to undue wear.

### VARIOGATE® 30-Series: Guillotine-device

The guillotine model can be used where there is limited space behind the loading area. This problem occurs when there is insufficient space for the outswing or a lateral displacement of the load.

#### Suitable for loads as follows:

- Height: 2.100 mm
- Choice of widths: 1.200, 1.600, 2.000 and 2.600 mm\*
- Depth: 1.400 mm

#### Installation space dimensions:

- Height: 3.275 mm
- Width: 1.600, 2.000, 2.400 and 3.000 mm
- Depth: Fixed supports: 350 mm  
Sliding component: 1.600 mm

\* Widths take the required space for manoeuvring on both sides into account.



### VARIOGATE® 30HI-Series: Guillotine-device

The sliding/folding model is a variant of the VARIOGATE® 30 guillotine device and is ideal for use in areas where, besides the overall height, the available depth behind loading opening is limited.

#### Suitable for loads as follows:

- Height: 1.600 mm
- Choice of widths: 1.200, 1.600 and 2.000 mm\*
- Depth: 1.200 mm

#### Installation space dimensions:

- Height: 2.650 mm
- Width: 1.600, 2.000 and 2.400 mm
- Depth: Fixed supports: 495 mm  
convertible component: 1.700 mm

\* Widths take the required space for manoeuvring on both sides into account.



## VARIOGATE® Barrier type

For more complex situations with limited room to manoeuvre or where rolling bridges are used, the barrier concept developed by Variogate is the perfect solution. This barrier is also a safe solution in environments with hinged doors.

A specific transfer system between both mechanical barriers directly controls the construction: when one barrier is opened, the other is immediately closed automatically. There are two versions for this solution available.

### VARIOGATE® 90-Serie: Barrier-Type

A barrier device where the goods are supplied or removed directly behind the plug-in opening to the left or right-hand side. The upper barriers are equipped with a retraction mechanism that also supports the operation, making the device easy to operate. The retractable upper barriers keep the required installation height to a minimum.

#### Suitable for loads as follows:

- Height: Unlimited
- Widths: On request
- Depth: On request

#### Installation space dimensions:

- Height: Device width + 510 mm
- Widths: On request
- Depth: On request

*\* Widths take the required space for manoeuvring on both sides into account.*

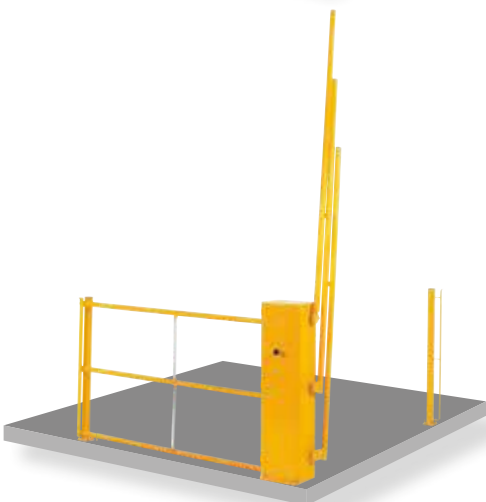

### VARIOGATE® 180-Serie: Barrier-Type

Barrier device for use in situations in which the goods are transported directly to or from the rear. The upper barriers (front and rear) are equipped with a retraction mechanism that also supports operation, making the device light to operate. These retractable upper barriers keep the required installation height to a minimum.

#### Suitable for loads as follows:

- Height: Unlimited
- Choice of widths: 1.000 up to 2.400 mm
- Depth: 1.300 mm

#### Installation space dimensions:

- Height: Device width + 430 mm
- Widths: 1.600 up to 3.000 mm
- Depth: 1.600 mm

*\* Widths take the required space for manoeuvring on both sides into account.*

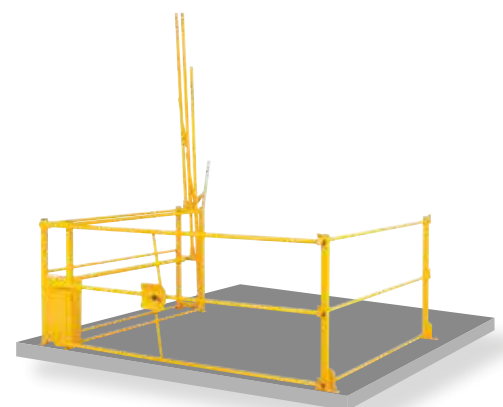



## Quality guarantee

The quality is substantiated and guaranteed  
By a TUV certificate issued following  
Extensive strength calculations and physical tests  
that have been assigned to the VARIOGATE®.

### VARIOGATE® 10-Series

The VARIOGATE® 10-Series is a pivoting loading gate design. The movable part of the gate lifts partly over the goods.

#### Suitable for loads as follows:

- Height: 1.600 mm
- Choice of Widths: 1.200, 1.600, 2.000 and 2.600 mm\*
- Depth: 1.400 mm

#### Installation space dimensions:

- Height: 2.150 mm
- Width: 1.600, 2.000, 2.400 and 3.000 mm
- Depth: Fixed supports: 900 mm  
Pivoting component: 1.900 mm
- Turning radius: 2.250 mm  
(measured from the floor edge)

\* Widths take the required space for manoeuvring on both sides into account.



### VARIOGATE® 360-Series

The VARIOGATE® 360 models offer a solution in situations where the space behind the loading opening area is limited, unloading is done with a hoist and/or a lot of height is required for loading. VARIOGATE® rotating models are suitable for areas where there are no height restrictions and for loads weighing up to approx. 2.000 kg. (Delivery includes a metal loading ramp.)

#### Suitable for loads as follows:

- Height: Unlimited
- Width: 1.300 mm\*
- Depth: 1.400 mm

#### Installation space dimensions:

- Height: 1.150 mm
- Width: 2.351 mm
- Depth: 1.700 mm
- Turning circle: 2.121 mm

\* Widths take the required space for manoeuvring on both sides into account.





## Accessories

In addition to the large portfolio of safety pallet gate systems, Collini Sistemi also offers various accessories. These products are at a further increase of the safety of various high

leveled individual situations; like shielding entrances, marking lifting points and more, the possibilities are endless!

### Aluminum chequer plate

For situations in which a chequer plate is preferred to protect the floor, we deliver chequer plates with a 5 or 2 bar pattern in our VARIOGATES® cantilever gates. Our chequer plates are also from stock available in various standard sizes. Chequer plates are applied for various purposes. For instance to protect landing edges or underlying foundations and materials, but also to demarcate pallet stacking frames.



### Safety netting

From now on we can also supply safety nets from stock. Available in lengths of 1.40 – 1.80 – 2.20 and 2.80 metres wide, suitable for the standard Variogate systems. Safety nets protect smaller sized goods from damage caused by a fall from a higher level. They also prevent injury to pedestrians walking at the lower level. Made to size nets are also available upon request.

### Marking tape

To add additional marking to your pallet stacking frame, we deliver various tapes. These tapes are easily made to fit the right dimensions and properly mark the pallet stacking frame. Marking is easy and can be done in various ways, for instance on the entresol or on the front of entresol's edge. This product offers maximum flexibility!



### VARIOGATE® additional fencing

If a situation requires additional fencing to fill in the opening, we have perfect solutions available. This fencing is easily made to fit and can be assembled just as easy. Furthermore, this fencing is equipped with a toe board, while its design enables different configurations.





## Customized solutions

For situations where the specifications of the VARIOGATE® series do not meet your requirements, Collini Sistemi can provide you with a customized solution. This could be the case when, for example,

there is a (fire)door, low headroom or an overhead crane. We can offer you a range of solutions for these situations. All of our products are made in a standard RAL1028, yellow colour but there is a choice in other colours as well.

### Made to size solutions

If your situation deviates too much from the solutions in our standard VARIOGATE® range, we can offer you a custom-made solution. This concerns, for example, situations with limited head height, limited depth or loading points where a (fire-proof) door is placed in the opening. If you fill in the enquiry form at the back of this brochure and return it to us, we can analyse your situation and prepare a customer-specific quotation for you, if necessary.



### Stainless steel and galvanized

Basically, all VARIOGATE® apparatus can also be produced as a special in a stainless steel version. Particularly for the food and pharmaceutical industries this is often mandatory.

In addition to that, we offer the possibility to produce a VARIOGATE® in a galvanized version.

### Deviating colours

A standard VARIOGATE® is provided with a high quality powder coating in RAL1028 (yellow). In addition, it is possible to produce the devices as a special in a different RAL colour according to (your) customers' specifications.

For prices, possibilities and delivery times please contact our sales team.









## Dimension detail forms

It is essential that the dimensions for a proper installation and good operating of the VARIOGATE® are correct. That is why Collini Sistemi welcomes the opportunity to assess the situation on site.

Getting the correct information is vital to ensure the quality of the solution!

# Enquiry Form

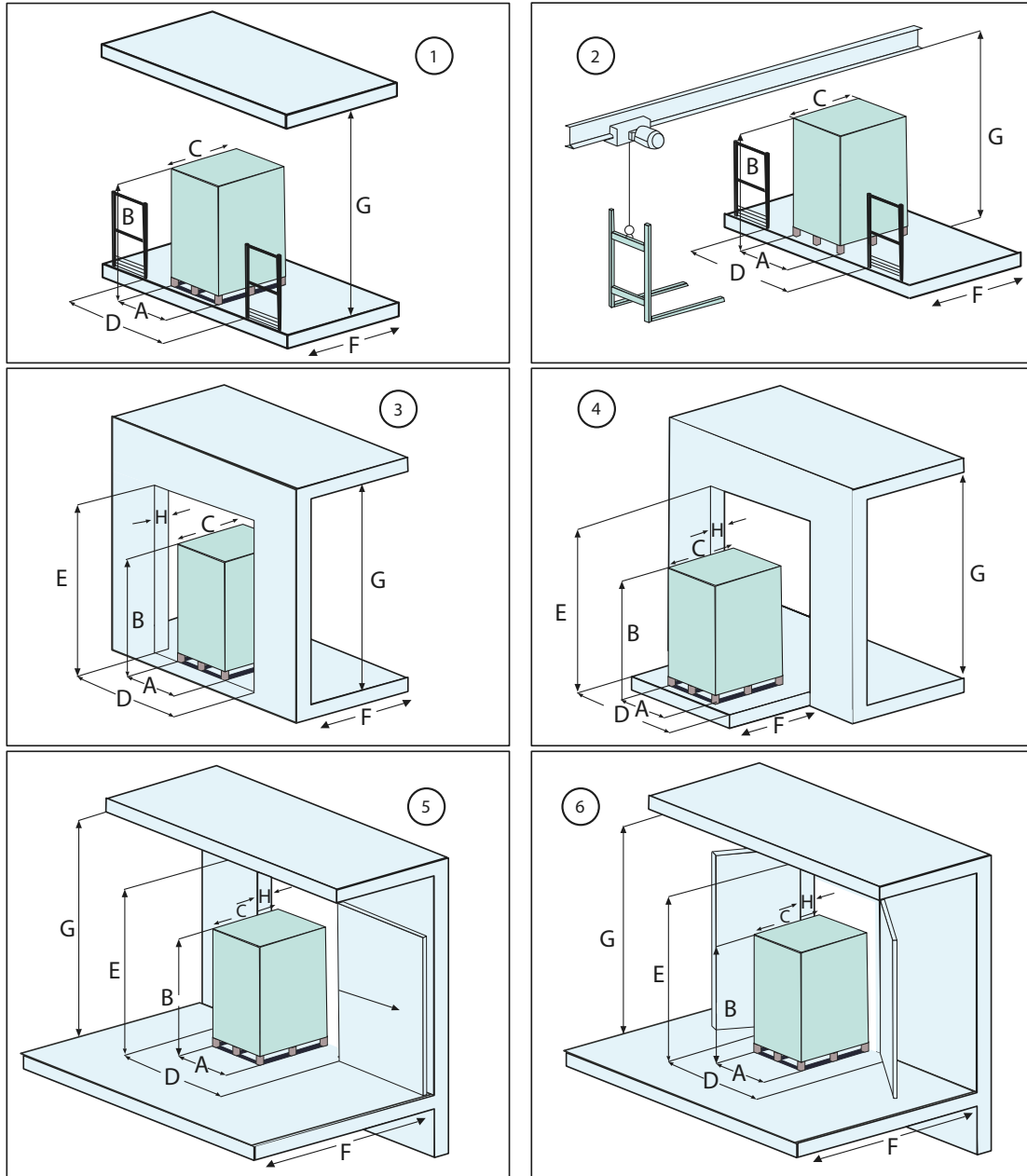

Please mark the current situation

Situation 1       2       3       4       5       6

A. Maximum width of the pallet = .....MM  
 B. Maximum height of the pallet = .....MM  
 C. Maximum depth of the pallet = .....MM  
 D. Available opening (width) = .....MM  
 E. Height of opening = .....MM

F. Available depth = .....MM  
 G. Available height behind the opening = .....MM  
 H. Distance from front side to the back of the door = .....MM

Type of surface:

To which side the goods are to be transported:  
 To the back / sideways

## References

During the past 35 years, we have been working on improving and making the workplace safer. Over the years we have worked for many large and small businesses in all parts of Europe.

Below you will find several photos of projects from Variogate which have been completed through the years.

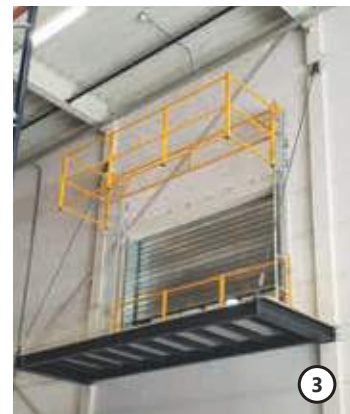





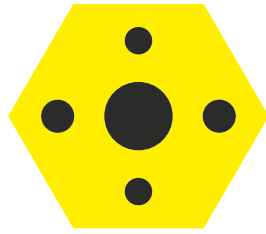

# collini sistemi

## Collini Sistemi

Via Oltrebrenta, 21  
35027 Noventa Padovana (PD)  
Tel: +39 049 504419  
E-Mail: [info@collinisistemi.it](mailto:info@collinisistemi.it)  
Website: [www.collinisistemi.it](http://www.collinisistemi.it)

---

Collini Sistemi is specialized in a number of very high quality products which all share the same characteristics to create a safe and pleasant workplace.

This brochure provides you with an overview of our products.

---

Also in our Product Range: Vigil Anti-slip

